



INTERFACE SERIES

Installation & Operation Instructions
AIM2

Phone: 1-888-967-5224
Website: workaci.com

GENERAL INFORMATION

The AIM2 optically isolates an analog (voltage or current) input signal from its corresponding output signal. It will accept any input signal between 0 and 20 VDC, or 0 and 20 mA, and output any signal within those ranges. The AIM2 has preset or adjustable inputs and preset or adjustable outputs that can be either voltage or current. The current signals on the input or output can be either sink or source. The AIM2 requires one external 24 VAC isolation transformer with floating secondary for power. It has an onboard 24 VAC isolation transformer to supply power to the isolated output. The AIM2 is field calibratable, however, factory calibration is available upon request for an additional charge. This will speed up installation time for the end user.

MOUNTING INSTRUCTIONS

Ground yourself to discharge static electricity before touching any electronic equipment, as some components are static sensitive. The interface device can be mounted in any position. If circuit board slides out of snap track, a non-conductive "stop" may be required. Use only fingers to remove board from snap track. Slide out of snap track or push up against side of snap track and lift that side of the circuit board to remove. **Do not flex board. Do not use tools.**

WIRING INSTRUCTIONS

PRECAUTIONS

- **Remove power before wiring. Never connect or disconnect wiring with power applied.**
- **When using a shielded cable, ground the shield only at the controller end. Grounding both ends can cause a ground loop.**
- **This device needs to have its own Isolated Transformer. This transformer cannot be connected/or shared with any other device. It is recommended you use an isolated UL-listed class 2 transformer.**
- **All wiring must comply with all local and National Electric Codes.**

FIGURE 1: DIMENSIONS

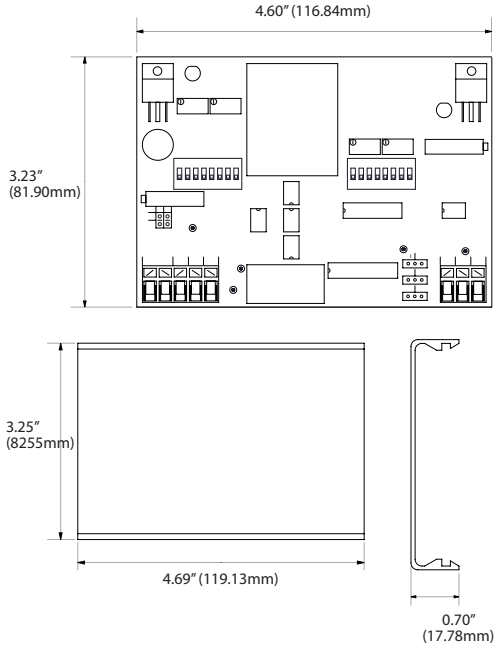
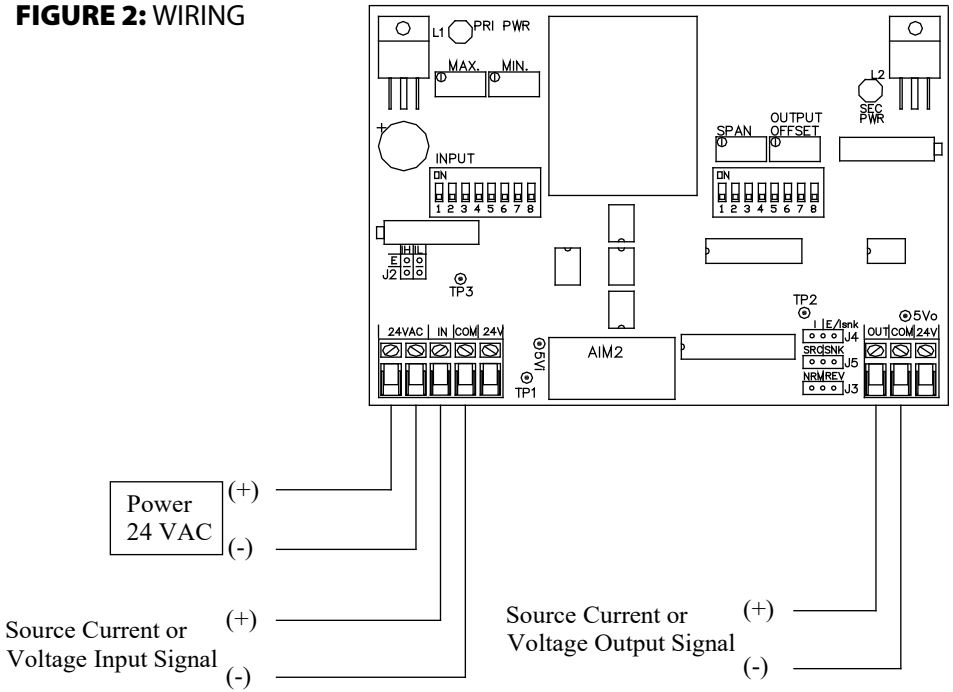
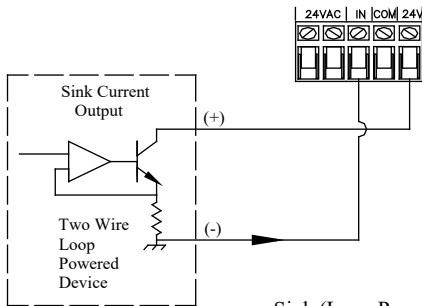

FIGURE 2: WIRING



Sink (Loop Powered) Current Input Connections using Internal VDC Supply



Sink (Loop Powered) Current Output Connections using External VDC Supply

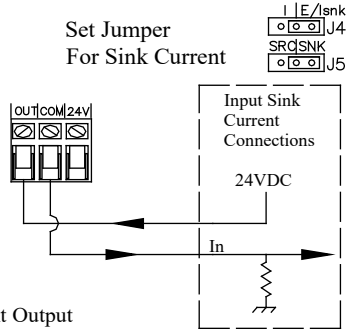

Sink (Loop Powered) Current Output Connections using Internal VDC Supply

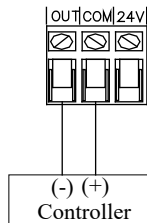

The AIM2 is factory set as follows, unless otherwise specified: All DIP switches are set to OFF and will not produce a proper signal output. Be sure to set switches to your required input and output ranges before powering. See “SETTING AIM2 INPUT” below.

The AIM2 can be field calibrated to your specifications using the “adjustable” setting on the DIP switches. See “SETTING AIM2 INPUT” below.

STEP 1) WIRING CONNECTIONS

With the power OFF, make the following connections:

Connect a 24 VAC power supply to the 24VAC terminals of the AIM2. Connect the input signal common (-) to the COM input terminal of the AIM2, and the input signal positive (+) to the IN input terminal of the AIM2.

Connect the output signal common (COM) and the output signal positive (OUT) to their respective terminals on the controlled device.

SETTING AIM2 INPUT

DIP switches determine input ranges. Jumper block J2 is selectable for input voltage (E), current low 0 - 1mA (IL), or current high 0 - 20mA (IH) input signal. A current input can be either sinking or sourcing signal. Explanation of “Source” and “Sink”:

Source – A signal where the positive (+) modulates and uses the negative (-) as the common. (Most prevalent in the industry)

Sink – A signal where the negative (-) modulates and uses the positive (+) as the common.

FOR PRESET VOLTAGE INPUT RANGES: Make the following switch settings on input DIP switch. Put Jumper J2 in (E) position (or Horiz.) for voltage. See **Table 1**.

FOR PRESET CURRENT INPUT RANGES: Make the following switch settings on input DIP switch. Put Jumper J2 in (IH) position for current. See **Table 2**.

TABLE 1: VOLTAGE INPUT RANGE

VOLTAGE INPUT	INPUT DIP SWITCH
0 – 5V	1,6 ON..... all others off
0 – 10V	1,4,6 ON.....all others off
0 – 15V	1,5,6 ON.....all others off
0 – 20V	1,4,5,6 ON.....all others off
1 – 5V	1,7 ON.....all others off
2 – 10V	1,4,7 ON.....all others off
3 – 15V	1,5,7 ON.....all others off
4 – 20V	1,4,5,7 ON.....all others off
0 – 1V	2,6 ON.....all others off
Adj. 1 – 9V	3,8 ON.....all others off
Adj. 9 – 20V	3,4,5,8 ON.....all others off

FIGURE 3: JUMPER SETTINGS

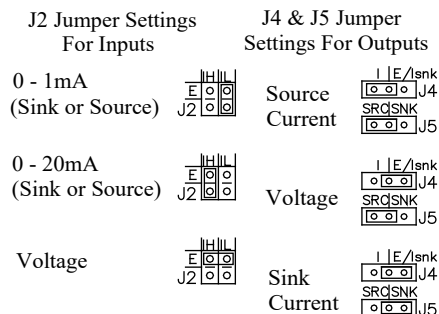

J3 Jumper Setting For Direct Or Reverse Acting Output

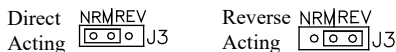

TABLE 2: CURRENT INPUT RANGE

CURRENT INPUT	INPUT DIP SWITCH
0 – 20 mA	1, 6 ON..... all others off
4 - 20 mA	1,7 ON.....all others off
0 - 1 mA	2, 6 ON.....all others off
Adj. 4 -20 mA	3, 8 ON.....all others off



CALIBRATIONS OF INPUT SIGNAL OTHER THAN PRESETS SHOWN ON TABLE

- 1.) If you have an input range other than any presets shown above, set the input DIP switches to one of the three Adj. settings. See inputs above in bold type.
- 2.) Apply the maximum of the input signal to terminals IN and COM. With a volt meter measure the voltage from TP1 to the AIM2's input side common (COM). Turn the input Max. pot until the meter reads 5.00 ± 0.00 V. The maximum of the input signal is now calibrated.
- 3.) If the minimum of the input signal is zero, set input DIP switches 7 and 8 OFF and 6 ON.
- 4.) If the minimum of the input signal is other than zero, set maximum as in step 2, and use the following steps to set the minimum:
 - A.) Set switch 8 ON and 6 and 7 OFF.
 - B.) Produce the minimum signal value at the input terminal (IN).
 - C.) Measure the voltage between the TP1 test point and COM. Record or remember.
 - D.) Now measure voltage between the TP3 test point and COM. Adjust the input MIN pot until the voltage at TP3 is equal to the voltage recorded at TP1. The minimum and maximum input signals are now calibrated.

SETTING AIM2 OUTPUT

FOR PRESET VOLTAGE OUTPUT RANGES: Make the following switch settings on output DIP switches. Set jumper J4 for E/Isnk (voltage/current sink), and J5 for SRC (source) output signal. See **Table 3**.

FOR PRESET CURRENT OUTPUT RANGES: Make the following switch settings on output DIP switch. If Source, set Jumper J4 to I and J5 to SRC. If Sink, set J4 to E/Isnk, and J5 to SNK. See **Table 4**.

TABLE 3: VOLTAGE OUTPUT RANGE

VOLTAGE OUTPUT	OUTPUT DIP SWITCH
0 – 5 V	1, 2, 4, 5 ON..... all others off
1 – 5 V	1, 3, 4,6 ON.....all others off
0 - 10V	4, 5 ON.....all others off
2 – 10 V	1,4, 7 ON.....all others off

TABLE 4: CURRENT OUTPUT RANGE

VOLTAGE OUTPUT	OUTPUT DIP SWITCH
0 – 20 mA	1, 2, 4, 5 ON..... all others off
4 - 20 mA	1, 3, 4,6 ON.....all others off

FOR CALIBRATION OF AN ODD OUTPUT SIGNAL

Before proceeding, you must have already set up the input signal. If not, return to page 3 and "SETTING AIM2 INPUT".

Output ranges are selectable on the output DIP switch by setting offset (minimum signal) and spans available (maximum minus offset) are shown below. Find out if you can use a preset range by subtracting the minimum output signal (or offset) from the maximum. For example, a 3.4 to 9.4 V signal output equals a 6 volt range, which is available as a preset, and the 3.4 volt offset can be adjusted. Any span not listed below will have to be set from one of the adjustable range switch settings.

TO SET PRESET OUTPUT SPANS (Reference only switches 1 through 4, others are for OFFSET - See **Table 5**).

TABLE 5: PRESET OUTPUT SPANS

VOLTAGE OUTPUT	OUTPUT DIP SWITCH
1V or 4mA	1,2,3,4 ON..... 1, 2, 3, 4 ON
3V or 12mA	2,3,4 ON..... 1 OFF
4V or 16mA	1,3,4 ON..... 2 OFF
5V or 20mA	1,2,4 ON..... 3 OFF
6V	3,4 ON.....1,2 OFF
7V	2,4 ON.....1,3 OFF
8V	1,4 ON.....2,3 OFF
10V	4 ON.....1,2,3 OFF
Adj. 1 – 11V	1,2,3 ON.....4 OFF
Adj. 10 – 20V	None ON.....1,2,3,4 OFF
Adj. 4 – 20mA	1,2,3 ON.....4 OFF



TO SET ADJUSTABLE OUTPUT SPANS

If your output span is not a listed preset, set the span DIP switches 1 through 4 to one of the three adjustable ranges (just above in bold), and the offset switches to the adjustable range by placing switch 8 ON, and 5,6,7 OFF. Give the AIM2 the maximum input signal and adjust the SPAN pot until the required span is reached on the output terminals.

TABLE 6: PRESET OUTPUT OFFSETS

VOLTAGE OUTPUT	OUTPUT DIP SWITCH
0V or 0mA	5 ON..... 6, 7, 8 OFF
1V or 4mA	6 ON.....5, 7, 8 OFF
2V or 8mA	7 ON.....5, 6, 8 OFF

Three preset output signal offsets are available. These will raise the entire span by the amount indicated, above zero. For example, an 8V span with a 2V offset will give you a 2 – 10V output signal. If your offset (or minimum output) is zero, set switch 5 ON and switches 6,7,8 OFF. See **Table 6**.

ADJUSTABLE OUTPUT OFFSETS

If your offset is not 0, 1, or 2 volts, you will need to adjust for your offset. The offset can be adjusted from 0 to approximately 10V.

Adjustable: 8 ON.....5,6,7 OFF

Generate the minimum input signal at the input terminals IN and COM and calibrate the output OFFSET pot until the offset required is reached (check with a voltmeter at output terminals OUT and COM).

From this point on, no further DIP switch changes are necessary. Toggle back and forth between the maximum and minimum to check the accuracy of the calibration. If the span (or maximum of the output) needs adjustment, turn the span pot. If the offset (or minimum) needs adjustment, turn the offset pot. Repeat until calibrated correctly.

POWER UP AND CHECKOUT

STEP 2) POWER UP

Turn on the 24 VAC power supply. Both power indicators on the AIM2 will light.

STEP 3) OPERATION

The AIM2 will now operate to your specifications, or the standard settings from the factory. If no field calibrations were made, then the AIM2 will accept a 0 to 5 volt DC input signal and produce an isolated and proportional 0 to 5 volt DC output signal. For example, a 3.50 volt input signal will produce a 3.50 volt DC output signal.

PRODUCT SPECIFICATIONS

NON-SPECIFIC INFORMATION	
Supply Voltage:	24 VAC (+/- 10%), 50/60 Hz
Supply Current:	200 mA maximum
Input Voltage Signal Preset Ranges:	0-5V, 0-10V, 0-15V, 0-20V, 1-5V, 2-10V, 3-15V, 4-20V, 0-1V
Input Current Signal Preset Ranges:	0-20 mA, 4-20 mA, 0-1 mA
Input Signal Adjustable Voltage Span:	1 VDC (Minimum) to 20 VDC (Maximum)
Input Signal Adjustable Voltage Offset:	From 0 to 20 VDC
Input Signal Adjustable Current Span:	4 mA (Minimum) to 20 mA (Maximum)
Current Offset:	From 0 to 20 mA
Input Voltage Impedance:	9,500Ω
Input Current Impedance:	250Ω +/-1%
Output Voltage Signal Preset Ranges:	0-5 VDC, 1-5 VDC, 0-10 VDC, 2-10 VDC
Output Current Signal Preset Ranges:	0-20 mA, 4-20 mA
Output Signal Adjustable Voltage Span:	1 VDC (Minimum) to 20 VDC +/- 1 VDC (Maximum)
Output Signal Adjustable Voltage Offset:	From 0 to 10 VDC
Output Signal Adjustable Current Span:	0 mA (Minimum) to 20 mA (Maximum)
Output Signal Adjustable Current Offset:	From 0 to 20 mA
Output Voltage Impedance:	5,000Ω
Output Current Impedance:	500Ω
Accuracy:	+/- 3%
Linearity:	+/- 1%
Connections:	45° Captive screw Terminal Blocks
Wire Size:	12 (3.31 mm ²) to 22 AWG (0.33 mm ²)
Terminal Block Torque Rating:	0.5 Nm (Minimum); 0.6 Nm (Maximum)
Operating Temperature Range:	35 to 120°F (1.7 to 48.9°C)
Operating Humidity Range:	10 to 95% non-condensing
Storage Temperature:	-20 to 150°F (-28.9 to 65.5°C)

WARRANTY

The AIM2 Series is covered by ACI's Two (2) Year Limited Warranty, which is located in the front of ACI'S SENSORS & TRANSMITTERS CATALOG or can be found on ACI's website: www.workaci.com.



NOTES

NOTES



