



Application

The ZG-102 multiple actuator mounting bracket is designed for cases where it is necessary to mount two actuators to one shaft to provide extra torque.

The dual mounting bracket is typically used with the GK, AF and GM series actuators. This is due to the fact that each of these series are the highest torque range available.

Figures A and B demonstrates two different mounting configurations using the ZG-102 mounting bracket.

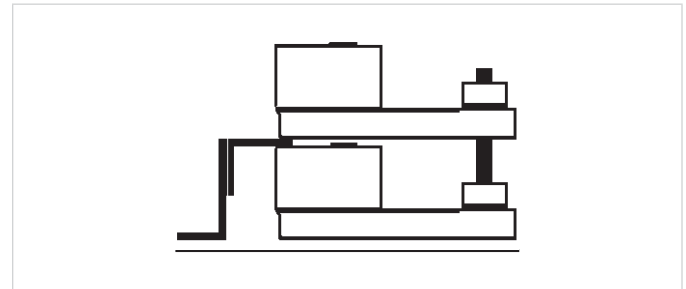

FIGURE A

The major advantage with this method is it requires less mounting area. The manual override, if available, cannot be used in this configuration.

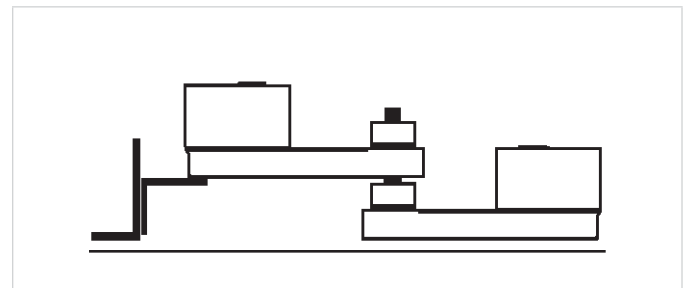
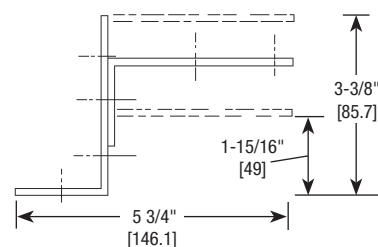
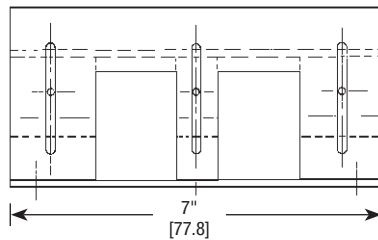
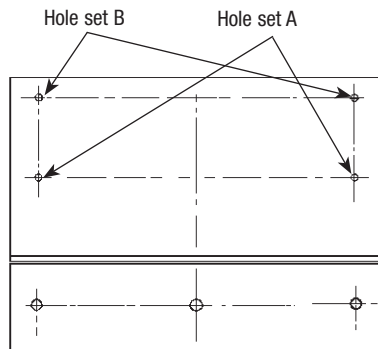

FIGURE B

The major advantages are that a shorter shaft is required and a lower profile is achieved.

Dimensions (Inches [mm])



Material	12 GA Galvanized
Weight	1.8 lbs.

OTHER CRANK ARM ADAPTOR KITS AND UNIVERSAL MOUNTING BRACKETS

KIT	MOUNTING BRACKET*	SUITABLE ACTUATOR
ZG-EFB	ZG-100, ZG-101	EF
ZG-AFB	ZG-100, ZG-101	AF, NF
ZG-AFB118	ZG-118 (included)	AF, NF
ZG-LF112	ZG-112 (Included)	LF
ZG-LF2	N/A	LF
ZG-LFC114	N/A	LF
ZG-ECON1	ZG-112 (Included)	LF
ZG-ECON2	ZG-112 (Included)	LF
ZG-TF112	ZG-113 (Included)	TF
ZG-TF2	N/A	TF
ZG-GMA	ZG-100, ZG-101, ZG-103, ZG-104	GK, GM
ZG-NMA	ZG-100, ZG-101, ZG-103, ZG-104	NM, AM

*Unless otherwise noted, mounting brackets are not included in crank arm adaptor kits.