

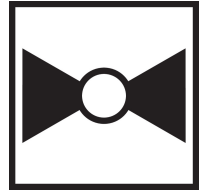

5-year warranty



Technical data

<b>Functional data</b>	Valve Size	6" [150]
	Fluid	chilled or hot water, up to 60% glycol
	Fluid Temp Range (water)	-22...250°F [-30...120°C]
	Body Pressure Rating	ANSI Class Consistent with 125, 232 psi CWP
	Close-off pressure Δps	50 psi
	Flow characteristic	modified equal percentage
	Servicing	maintenance-free
	Rangeability Sv	10:1 (for 30...70° range)
	Flow Pattern	2-way
	Leakage rate	0%
	Controllable flow range	90° rotation
	Cv	1579
	Maximum Velocity	12 FPS
	Lug threads	3/4-10 UNC
<b>Materials</b>	Valve body	Ductile cast iron ASTM A536
	Body finish	epoxy powder coating (blue RAL 5002)
	Spindle	416 stainless steel
	Spindle seal	EPDM (lubricated)
	Seat	EPDM
	Pipe connection	for use with ANSI class 125/150 flanges
	Bearing	RPTFE
	Disc	304 stainless steel
<b>Suitable actuators</b>	Non-Spring	DRB(X)

Product features

Flow/Mounting details

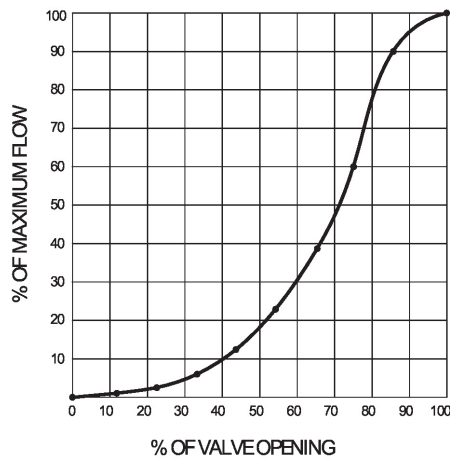

Dimensions

Dimensional drawings

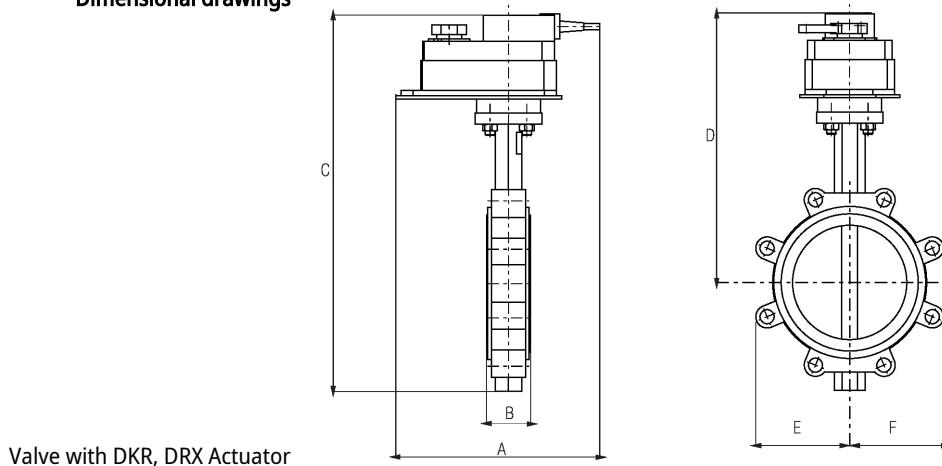

Valve with DKR, DRX Actuator

Type

DN

Weight [kg]  
[kg]

F6150HDU

150

8.6

A	B	C	D	E	F	Number of Bolt Holes
11.3" [286]	2.3" [58]	19.0" [483]	14.0" [355]	5.4" [137]	5.4" [137]	8

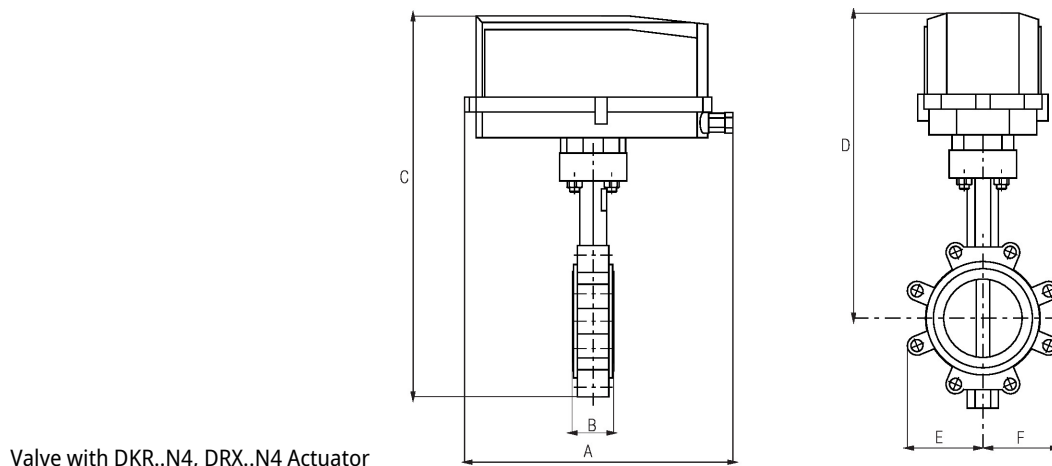

Valve with DKR..N4, DRX..N4 Actuator

A	B	C	D	E	F	Number of Bolt Holes
14.1" [358]	2.3" [58]	21.0" [533]	16.1" [408]	5.4" [137]	5.4" [137]	8

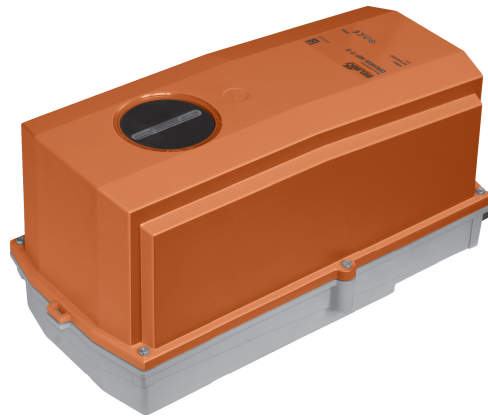

5-year warranty



## Technical data



<b>Electrical data</b>	Nominal voltage	AC/DC 24 V
	Nominal voltage frequency	50/60 Hz
	Power consumption in operation	12 W
	Power consumption in rest position	3 W
	Transformer sizing	10 VA (class 2 power source) / heater 36 VA
	Electrical Connection	Screw terminal (for 22 to 12 AWG wire)
	Overload Protection	electronic throughout 0...90° rotation
<b>Functional data</b>	Direction of motion motor	selectable with switch 0/1
	Manual override	under cover
	Running Time (Motor)	35 s / 90°
	Running time motor note	constant, independent of load
	Noise level, motor	45 dB(A)
	Position indication	Mechanically, 5...20 mm stroke
<b>Safety data</b>	Degree of protection IEC/EN	IP66/67
	Degree of protection NEMA/UL	NEMA 4X
	Enclosure	UL Enclosure Type 4X
	Quality Standard	ISO 9001
	Ambient temperature	-22...122°F [-30...50°C]
	Ambient temperature note	-40...50°C for actuator with integrated heating
	Storage temperature	-40...176°F [-40...80°C]
	Ambient humidity	Max. 100% RH
Servicing	maintenance-free	
<b>Materials</b>	Housing material	Die cast aluminium and plastic casing
<b>Footnotes</b>	Control Signal must be specified at time of order. Control cannot be changed via field wiring.	

## Accessories

Electrical accessories	Description	Type
	Battery backup system, for non-spring return models	NSV24 US
	Battery, 12 V, 1.2 Ah (two required)	NSV-BAT
	Auxiliary switch 1 x SPDT add-on	S1A
	Auxiliary switch 2 x SPDT add-on	S2A
	Feedback potentiometer 140 Ω add-on, grey	P140A GR
	Feedback potentiometer 5 kΩ add-on, grey	P5000A GR
	Feedback potentiometer 1 kΩ add-on, grey	P1000A GR
	Feedback potentiometer 2.8 kΩ add-on, grey	P2800A GR
	Feedback potentiometer 500 Ω add-on, grey	P500A GR
	Feedback potentiometer 10 kΩ add-on, grey	P10000A GR

Electrical installation

**✂ INSTALLATION NOTES**

-  Provide overload protection and disconnect as required.
-  Actuators may also be powered by DC 24 V.
-  For triac sink the Common connection from the actuator must be connected to the Hot connection of the controller. Position feedback cannot be used with a triac sink controller; the actuator internal common reference is not compatible.
- IN4004 or IN4007 diode. (IN4007 supplied, Belimo part number 40155).
- Actuators are provided with a numbered screw terminal strip instead of a cable.
- Meets cULus requirements without the need of an electrical ground connection.
- Warning! Live electrical components!**

During installation, testing, servicing and troubleshooting of this product, it may be necessary to work with live electrical components. Have a qualified licensed electrician or other individual who has been properly trained in handling live electrical components perform these tasks. Failure to follow all electrical safety precautions when exposed to live electrical components could result in death or serious injury.

**Wiring diagrams**

On/Off

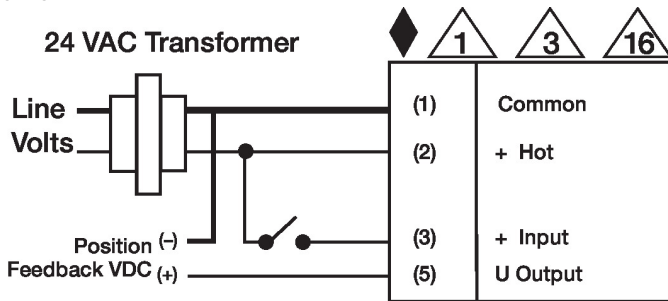

Floating Point

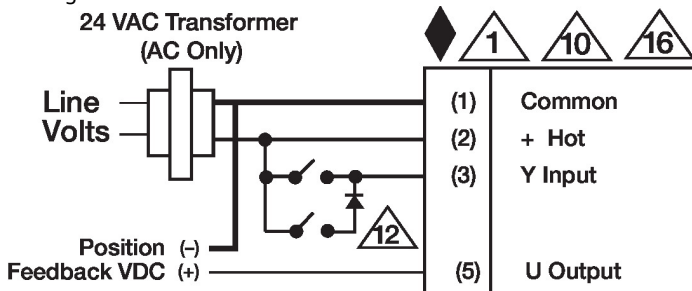

Dimensions