



H622-10

Solid-Core Transducer, 0 to 5 Vdc Output

Product Overview

The H622-10 is a current transducer that senses current (amperage) in the 0 to 10 A range. This represents the maximum current that can be applied to the monitored conductor. The H622-10 transforms the monitored current into a 0 to 5 Vdc output suitable for connection to building controllers, or other appropriate data acquisition equipment. The H622-10 requires no external power supply to generate its output.



* The CE mark indicates RoHS2 compliance. Please refer to the CE Declaration of Conformity for additional details.

Specifications



Sensor Power	Induced from monitored conductor
Insulation Class	600 Vac RMS (UL), 300 Vac RMS (CE)
Amperage Range	0 to 10 A
Frequency	50/60 Hz nominal
Temperature Range	-15 to 60 °C (5 to 140 °F)
Humidity Range	10 to 90% RH, non-condensing
Accuracy	±2% F.S. from 10% to 100% (range)
Response Time	2 seconds
Terminal Block Maximum Wire Size	24 to 14 AWG (0.2 to 2.1 mm ²)
Terminal Block Torque (nominal)	4 in-lbs (0.45 N-m)

Note: For CE compliance, conductor shall be insulated according to IEC61010-1. The product design provides for basic insulation only. For applications requiring double or reinforced insulation, please contact the factory.

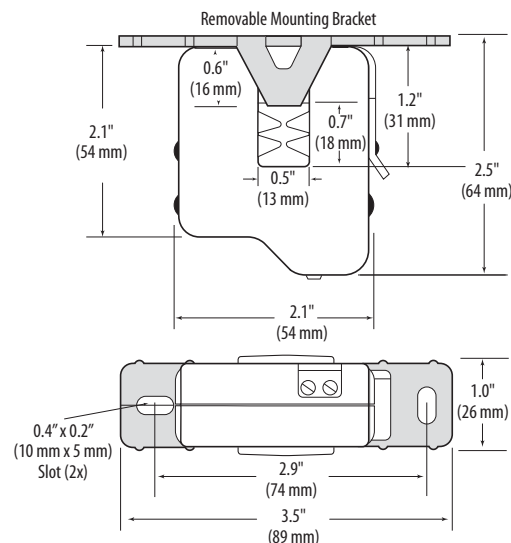
Dimensions



Regulatory Information



DANGER

HAZARD OF ELECTRIC SHOCK, EXPLOSION, OR ARC FLASH

- Follow safe electrical work practices. See NFPA 70E in the USA, CSA Z462 in Canada, or applicable local codes.
- Read and understand the instructions before installing the product. Follow the instructions during installation.
- Installation, wiring, testing or service must be performed only by qualified persons in accordance with all applicable codes and regulations.
- Install the product in an appropriate electrical and fire enclosure per local regulations.
- Do not use the product for life or safety applications.
- Do not install the product in hazardous or classified locations.
- Do not exceed the product's ratings or maximum limits.
- The product may use multiple voltage/power sources.
- Turn off ALL power supplying equipment before working on or inside the equipment.
- Use a properly rated voltage sensing device to confirm that all power is off.
- Do NOT depend on the product for voltage indication.
- Products rated only for basic insulation must be installed on insulated conductors.
- Current transformer secondaries (current mode) must be shorted or connected to a burden at all times.
- Remove all wire scraps and tools, replace all doors, covers and protective devices before powering the equipment.

Failure to follow these instructions will result in death or serious injury.

A qualified person is one who has skills and knowledge related to the construction and operation of this electrical equipment and installations, and has received safety training to recognize and avoid the hazards involved. NEC Article 100

If this product is used in a manner not specified by the manufacturer, the protection provided by the product may be impaired. No responsibility is assumed by the manufacturer for any consequences arising out of the use of this material.

Installation

1. Disconnect and lock out power.
2. Install the mounting bracket to the back of the electrical enclosure, no closer than 1/2" (12 mm) to an uninsulated conductor.
3. Place the conductor to be monitored in the sensing cavity of the current sensor. Ensure the latch is closed. See Notes section below for currents under 1 A or above 10 A.
4. Wire the output connections between the H622-10 and the controller (0 to 5 Vdc).
5. Reconnect power.
6. Scale the controller software to match the output of the H622-10.

Installation (Cont.)

Notes

For load currents greater than sensor maximum rating:

Use a 5 Amp (H681x series) Current Transformer (CT) as shown.

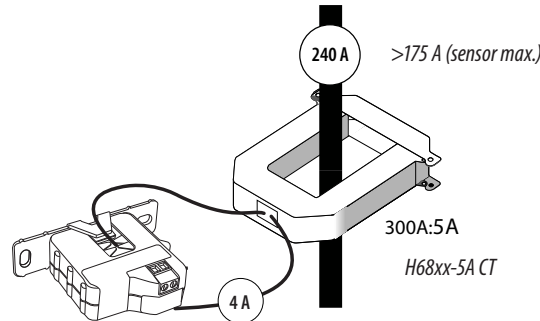

DANGER: 5A CTs can present hazardous voltages. Install CTs in accordance with manufacturer's instructions. Terminate the CT secondary before applying current.

NOTICE	
RISK OF EQUIPMENT DAMAGE	
<ul style="list-style-type: none"> • Never exceed the current sensor rating. • Derate the product's maximum current for the number of turns through the current sensor window using the following formula: Rated Max. Amps ÷ Number of Turns = Max. monitored Amps e.g. : 100A ÷ 4 Turns = 25 Amps max. in monitored conductor 	
Failure to follow these instructions can result in overheating and permanent equipment damage.	

For load currents less than sensor minimum rating:

Wrap the monitored conductor through the center hole and around the sensor body to produce multiple turns through the "window." This increases the current measured by the transducer.

Controller must be programmed to account for the extra turns. e.g., if four turns pass through the sensor (as shown) the normal controller reading must be divided by 4.

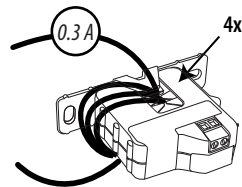

Wiring Example

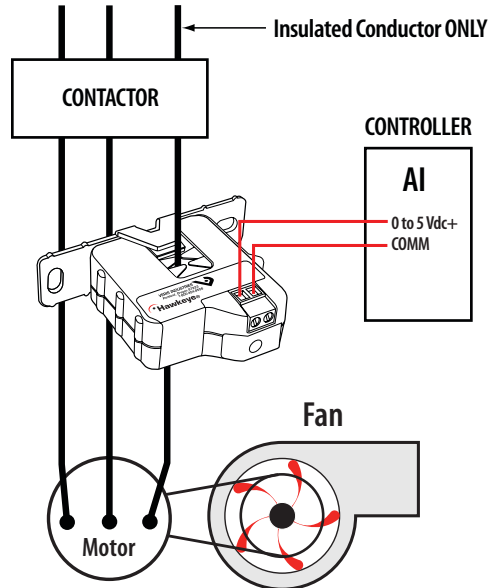

Calibration

Scale the controller software to match the current transducer's output (0 to 5 Vdc).

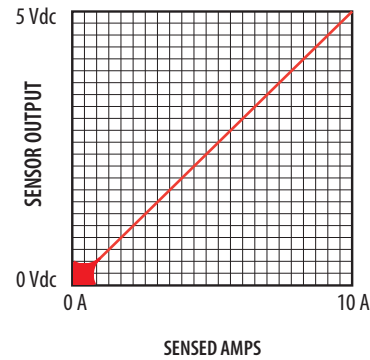

Troubleshooting

Issue	Solution
No reading at controller	<ul style="list-style-type: none"> • Check for control voltage at sensor (<5 Vdc). • Check for amperage in monitored conductor (>1 A). • Assure that sensor core mating surfaces are clean.